



**NEW**

- Stage V crane engine
- ZF TraXon gearbox

## SK597-AT4

- Possibility to drive with 10 ton axle load
- 48 meter radius / 7,000 kg max. / 1,700 kg max. tip load

 **SPIERINGS**  
MOBILE CRANES

# Your flexibility to the max



## Upper engine

With the newest emission regulations Spierings still chooses for two engines. The Stage 5 four Cylinder diesel engine (constant rpm) is mounted in the super structure. The engine and the hydraulic pumps are mounted in a high quality sound reducing cover.



## Truck cabin

The Spierings Crane is equipped with the latest design of interior. The new cab design is ergonomic and gives the driver optimum comfort. The driver's seat is equipped with air suspension. Air-conditioning, navigation, radio, Bluetooth car kit and heated and adjustable mirrors are standard.



## One job, one man

One operator can easily erect and operate the crane. No additional ballast or jib sections are required. A Spierings crane can at all times be operated by one operator. The operator has a perfect view out of the crane cab and with the optional mounted trolley camera even in the most difficult situations.

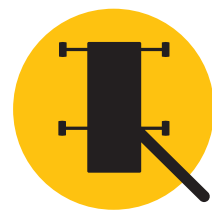

## Truck

Specially designed truck chassis for optimum torsion rigidity. As a result of the special construction, the maximum lifting capacity can be reached with minimum ballast, thus making extra ballast unnecessary.





### Hydraulic motions

All crane motions are hydraulic proportional controlled. This makes the crane easy to operate and gives maximum precision and efficiency.



### Steel pads

The crane is optional equipped with 4 steel pads (2x0,9 meter), mounted at the rear of the carrier. An auxiliary crane arm is fit for placing the steel pads.



### Setup in minutes

The fully automatic program to erect the Spierings Crane takes approx 8 minutes after the crane is set on its outrigger.

Four LED floodlights are mounted in the jib and tower.



Crane Cabin equipped with trolley camera display and touch screen.

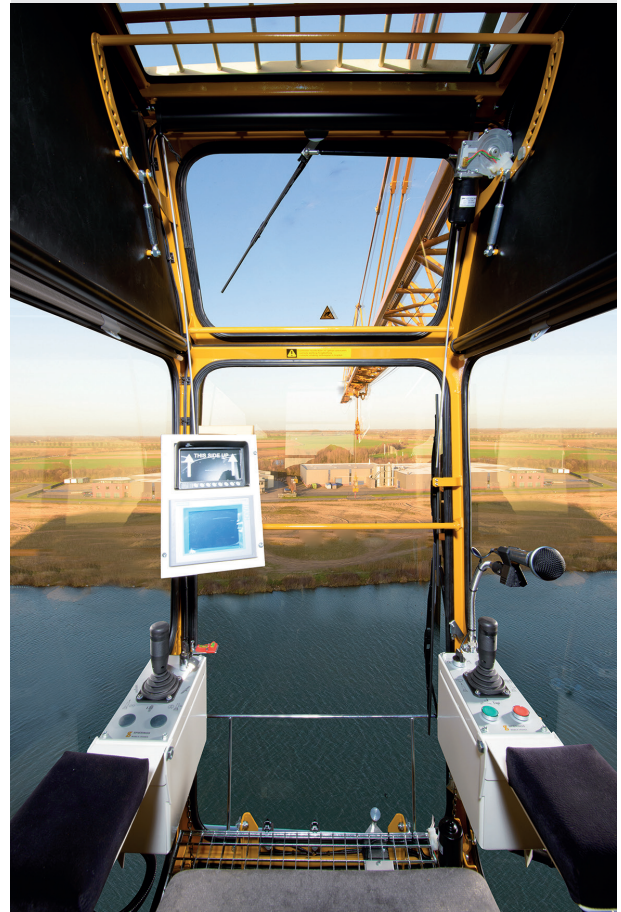

Auxiliary crane for placing the steel pads



The new truck cab interior design is fully equipped and gives the driver optimum comfort.



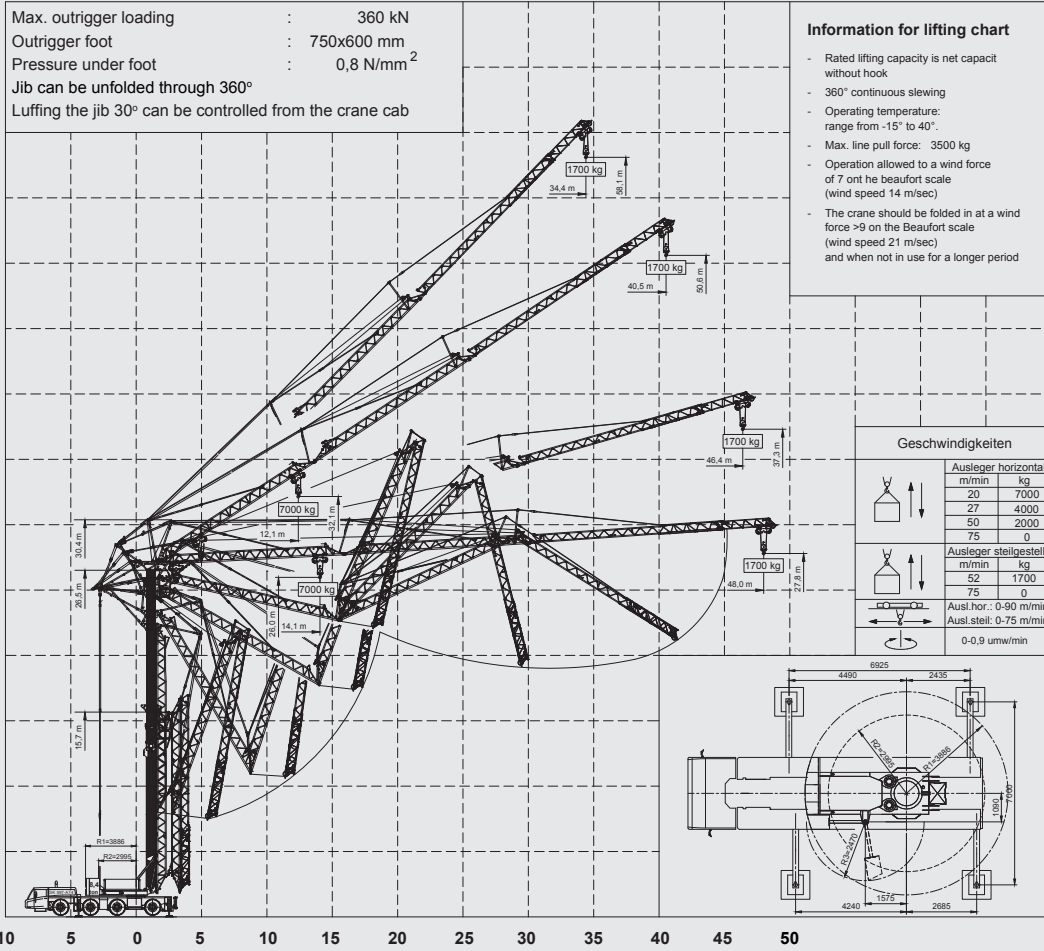

Änderungen vorbehalten

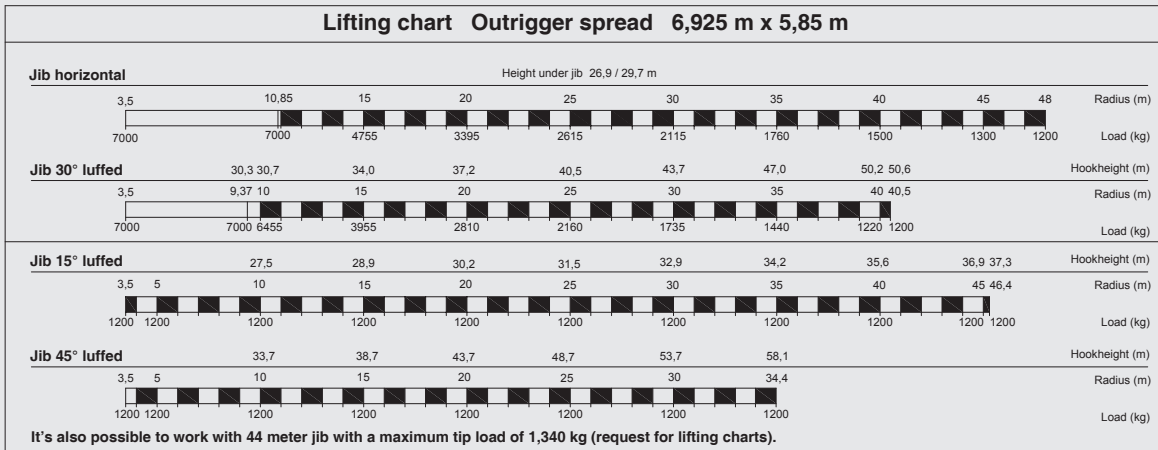
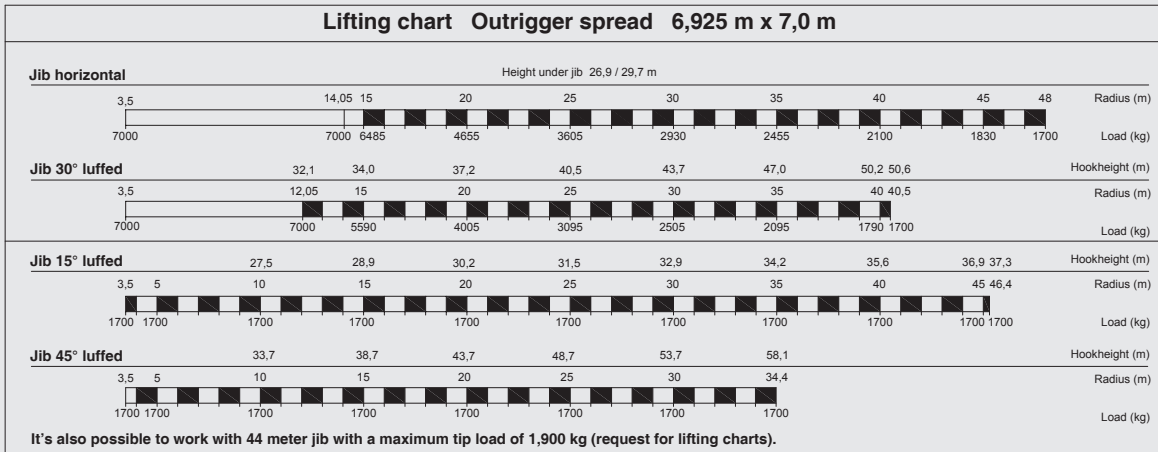

Changes subject to modifications

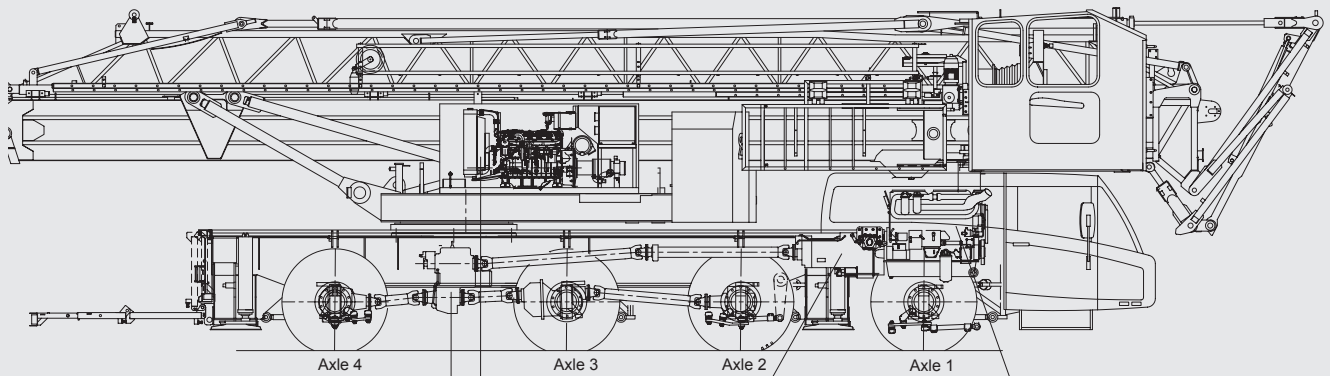

Transfer box:  
ZF VG2001/396  
Road gear  $i=0,89$   
Off road gear  $i=1,54$

Crane diesel engine  
Stage V

Gearbox  
ZF Traxon 12  
Automatic  
Dry plate clutch  
+ interarder

Carrier diesel engine:  
Euro VI  
DAF: MX11-330 (10,8 ltr)  
Power: 330 kW (1600 rpm)  
Torque: 2300 Nm (900-1150 rpm)

- |                               |  |                            |                                |
|-------------------------------|--|----------------------------|--------------------------------|
| Axle 1 :                      | Steer axle                                       | Tyres                      | : 445/75 R22,5                 |
| Axle 2 :                      | Steer drive axle (end reduction $i=6,35$ )       | Suspension                 | : Hydro-pneumatic on all axles |
| Axle 3 :                      | Non steered drive axle (end reduction $i=6,35$ ) | Stroke suspension cylinder | : 247 mm                       |
| Axle 4 :                      | Steer drive axle (end reduction $i=6,35$ )       | Max. speed carrier         | : 83 km/h                      |
| Kessler-axes with disc brakes |  | Overall weight             | : 48.000 kg                    |

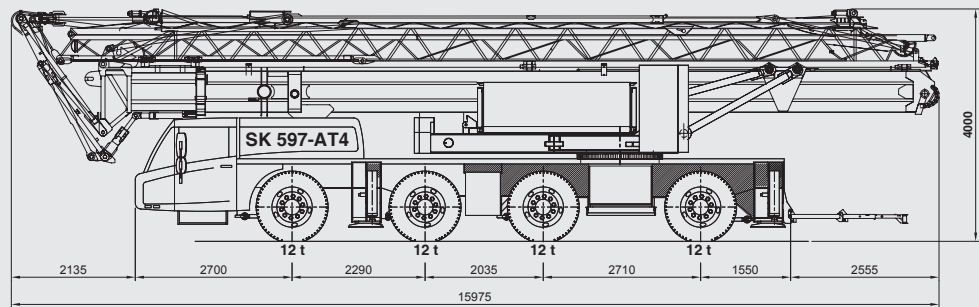
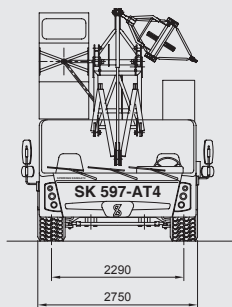
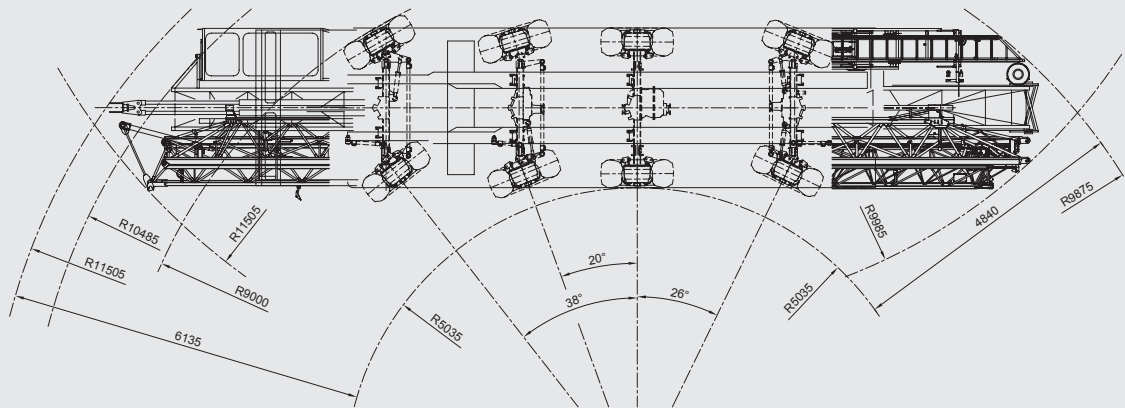

**48.000 kg overall weight**

**SPIERINGS**  
MOBILE CRANES

**Lift to the max.**

Spierings Mobile Cranes B.V.  
Merwedestraat 15  
5347 KZ Oss - The Netherlands  
PO Box 24, NL-5340 AA Oss

T +31(0) 412 69 77 77  
I [www.spieringscranes.com](http://www.spieringscranes.com)  
E [sales@spieringscranes.com](mailto:sales@spieringscranes.com)